

# SCALE-iFlex™ XLT Dual-Channel Plug-and-Play Gate Driver

- For power modules up to 2300 V
- Supports two-level and three-level applications
- $\geq 20\%$  higher converter power using the same hardware
- Ultra-compact, single-board solution
- Temperature readout (NTC) with reinforced isolation simplifies thermal management

Ready-to-Use Gate Driver Solution for 100 mm x 140 mm Half-Bridge Power Modules Up to 2300 V

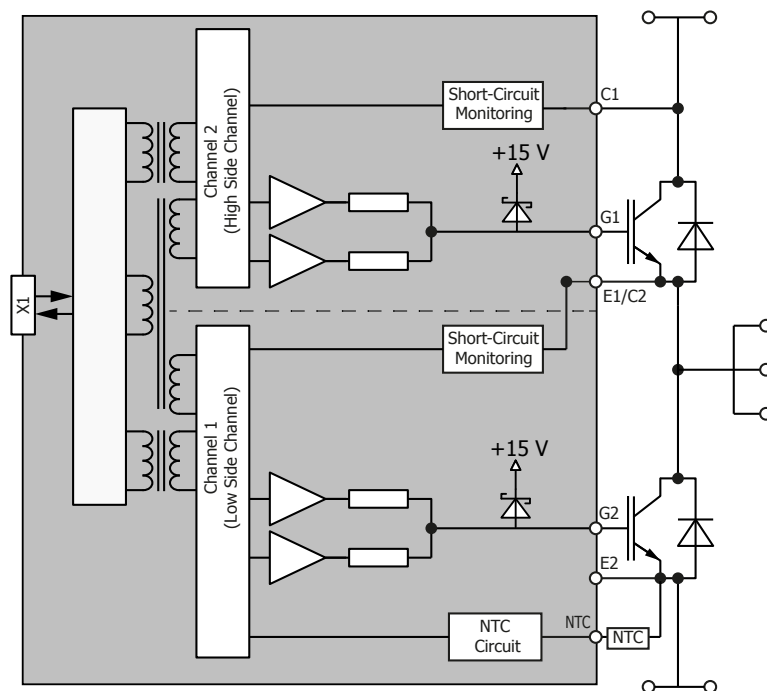

## Applications

- Wind converters
- Energy storage systems
- Photovoltaic converters
- Industrial drives

## Product Details

Part Number	Power Module	Voltage Class	Current Class	Package	Power Device Supplier
2SIXT0112T2A0-FF1800XTR17T2P5	FF1800XTR17T2P5	2300 V	1800 A	XHP	Infineon
2SIXT0112T2A0-CM1200DW-34T	CM1200DW-34T	1700 V	1200 A	LV100	Mitsubishi
2SIXT0112T2A0-CM1200DW-24T	CM1200DW-24T	1200 V	1200 A	LV100	Mitsubishi
2SIXT0112T2A0-2MBI1200XZF	2MBI1200XZF170-50	1700 V	1200 A	HPnC	Fuji



## Design Support

### Data Sheet

SCALE-iFlex XLT data sheet ([www.power.com/design-support/data-sheets/2sixt0112t2a0-data-sheet](http://www.power.com/design-support/data-sheets/2sixt0112t2a0-data-sheet))