

QH12TZ600Q

Qspeed™ 产品系列

汽车级600V/12A H系列SiC替代型二极管

产品概览

$I_{F(AVG)}$	12	A
RRM (额定反向耐压)	600	V
Q_{RR} (125°C下典型值)	30	nC
I_{RRM} (125°C下典型值)	2.2	A
软度 t_b/t_A (125°C下典型值)	0.65	

引脚分配

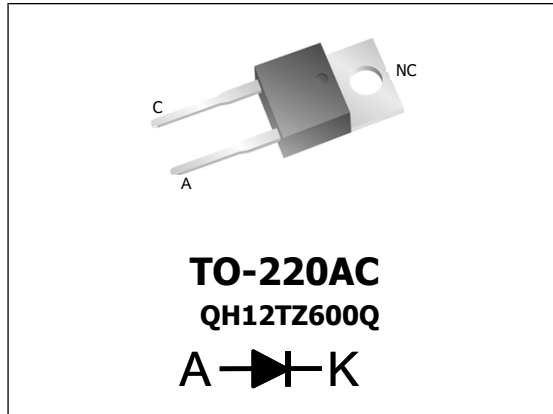

符合RoHS标准

封装采用无铅电镀和“绿色环保”模封料。
根据IEC 61249-2-21标准，不含卤素。

概述

该器件在所有600V硅二极管中具有最低的 Q_{RR} 。其恢复特性能提高效率、降低EMI并省去缓冲电路。可替代SiC二极管，在高开关频率应用中实现类似的高效率性能。

应用

- 车载充电器中的功率因数校正升压二极管
- 车载充电器输出整流管

特色

- 低 Q_{RR} 、低 I_{RRM} 、低 t_{RR}
- 可实现高 dI_F/dt 值(1000A/ μ s)
- 软恢复
- 符合AEC-Q101标准
- 晶圆厂、组装厂和测试厂均通过IATF 16949认证

优势

- 提高效率
 - 无需缓冲电路
 - 减少EMI滤波元件的尺寸和数目
- 可实现极快速开关

绝对最大额定值

绝对最大额定值是指一旦超过就可能使器件受损或缩短其使用寿命的极限值。不建议在此类条件下进行功能性工作。

符号	参数	条件	额定值	单位
V_{RRM}	峰值重复反向电压	$T_J = 25^\circ\text{C}$	600	V
$I_{F(AVG)}$	平均前馈电流	$T_J = 150^\circ\text{C}, T_C = 90^\circ\text{C}$	12	A
I_{FSM}	非重复峰值浪涌电流	60Hz, $\frac{1}{2}$ 周期, $T_C = 25^\circ\text{C}$	100	A
I_{FSM}	非重复峰值浪涌电流	$t = 28 \mu$ 正弦的 $\frac{1}{2}$ 周期, $T_C = 25^\circ\text{C}$	350	A
T_J	工作结温范围		-55至150	$^\circ\text{C}$
T_{STG}	存储温度		-55至150	$^\circ\text{C}$
	引线焊接温度	引线距壳体1.6mm, 10秒	300	$^\circ\text{C}$
V_{ISOL}	绝缘强度 (引线至散热片)	AC, TO-220	2500	V
P_D	功耗	$T_C = 25^\circ\text{C}$	61	W

热阻

符号	电阻从：	条件	额定值	单位
$R\theta_{JA}$	结到环境	TO-220	62	$^{\circ}\text{C}/\text{W}$
$R\theta_{JC}$	结到壳体		2.05	$^{\circ}\text{C}/\text{W}$

电气规格, $T_J = 25^{\circ}\text{C}$ (除非另有指定)

符号	参数	条件	最小值	典型值	最大值	单位	
直流特性							
I_R	反向电流	$V_R = 600\text{V}, T_J = 25^{\circ}\text{C}$	-	-	250	μA	
		$V_R = 600\text{V}, T_J = 125^{\circ}\text{C}$	-	0.6	-	mA	
V_F	正向电压	$I_F = 12\text{A}, T_J = 25^{\circ}\text{C}$	-	2.65	3.1	V	
		$I_F = 12\text{A}, T_J = 150^{\circ}\text{C}$	-	2.33	-	V	
C_J	结电容	$V_R = 10\text{V}, 1\text{MHz}$	-	34	-	pF	
动态特性							
t_{RR}	反向恢复时间	$dI/dt = 200\text{A}/\mu\text{s}$ $V_R = 400\text{V}, I_F = 12\text{A}$	$T_J = 25^{\circ}\text{C}$	-	11.6	-	ns
			$T_J = 125^{\circ}\text{C}$	-	20.5	-	ns
Q_{RR}	反向恢复电荷	$dI/dt = 200\text{A}/\mu\text{s}$ $V_R = 400\text{V}, I_F = 12\text{A}$	$T_J = 25^{\circ}\text{C}$	-	9.2	14	nC
			$T_J = 125^{\circ}\text{C}$	-	30	-	nC
I_{RRM}	最大反向恢复电流	$dI/dt = 200\text{A}/\mu\text{s}$ $V_R = 400\text{V}, I_F = 12\text{A}$	$T_J = 25^{\circ}\text{C}$	-	1.27	1.8	A
			$T_J = 125^{\circ}\text{C}$	-	2.2	-	A
S	软度系数 = $\frac{t_B}{t_A}$	$dI/dt = 200\text{A}/\mu\text{s}$ $V_R = 400\text{V}, I_F = 12\text{A}$	$T_J = 25^{\circ}\text{C}$	-	0.6	-	
			$T_J = 125^{\circ}\text{C}$	-	0.65	-	

元件工程师注意事项：H系列二极管的设计和结构采用肖特基技术。因此，元件工程师应规划其测试装置，使其与传统的肖特基测试装置类似。（详细信息请参考应用指南AN-300。）



图1. 反向恢复定义



PI-7614-041315

图2. 反向恢复测试电路

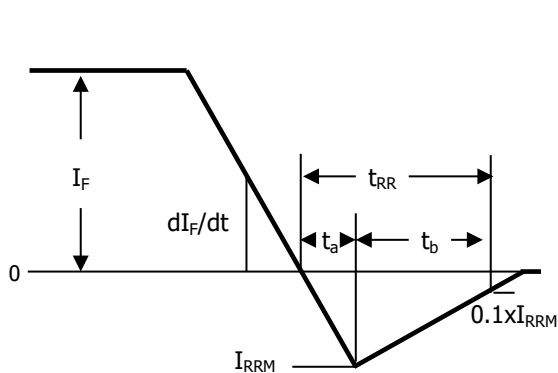
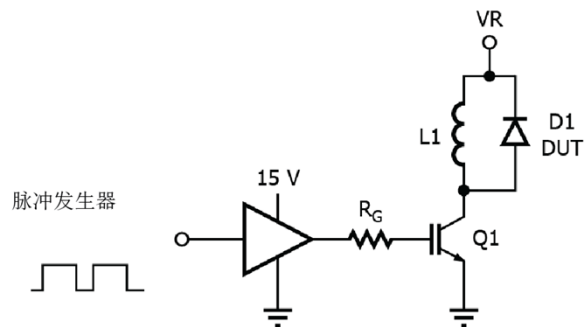
电气规格, $T_J = 25^\circ\text{C}$ (除非另有指定)



图3. I_F 相对于 V_F 的典型变化



图4. C_J 相对于 V_R 的典型变化

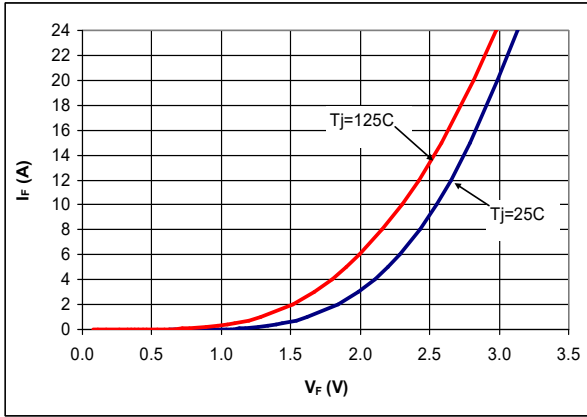

图5. Q_{RR} 相对于 I_F 的典型变化, $T_J = 125^\circ\text{C}$

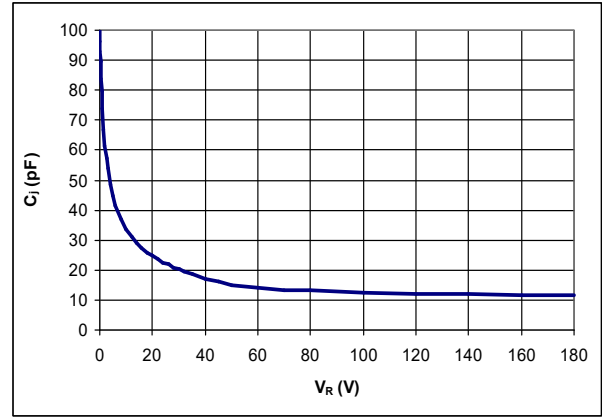

图6. t_{RR} 相对于 I_F 的典型变化, $T_J = 125^\circ\text{C}$

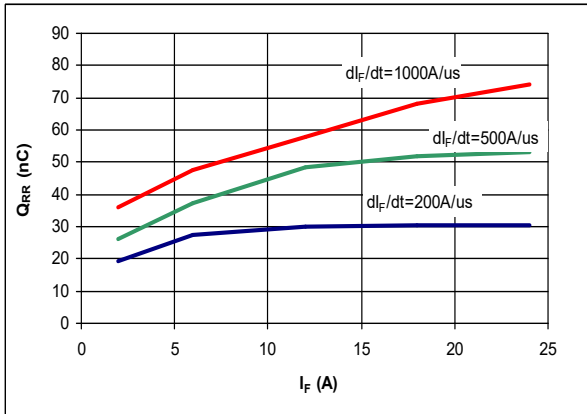

图7. 直流电流降额曲线

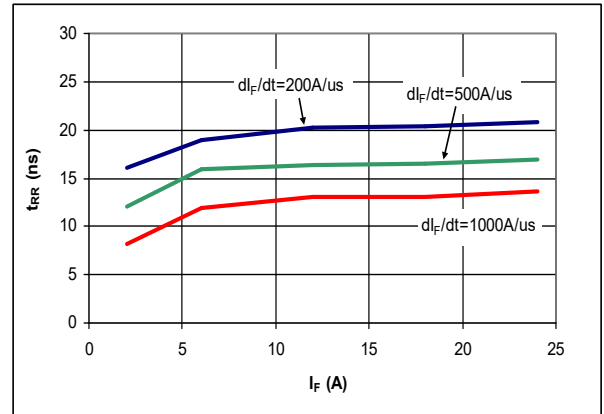

图8. 功率降额曲线

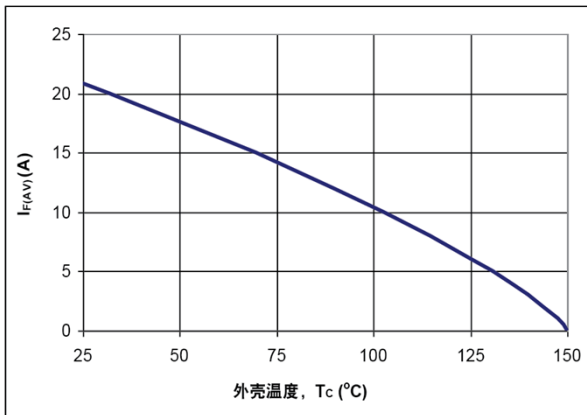

图9. I_F (峰值)相对于 T_c 的变化, $f = 70\text{kHz}$

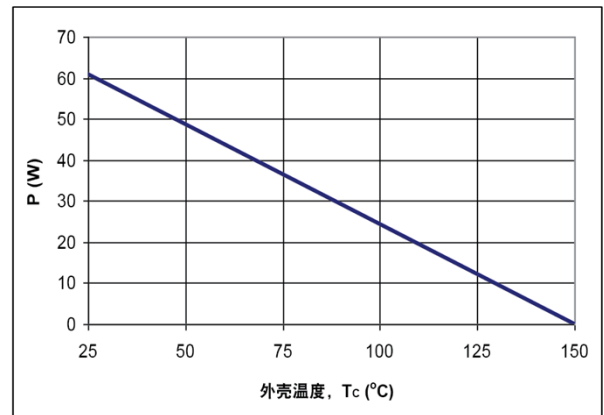

图10. 归一化最大动态热阻抗

外形尺寸图

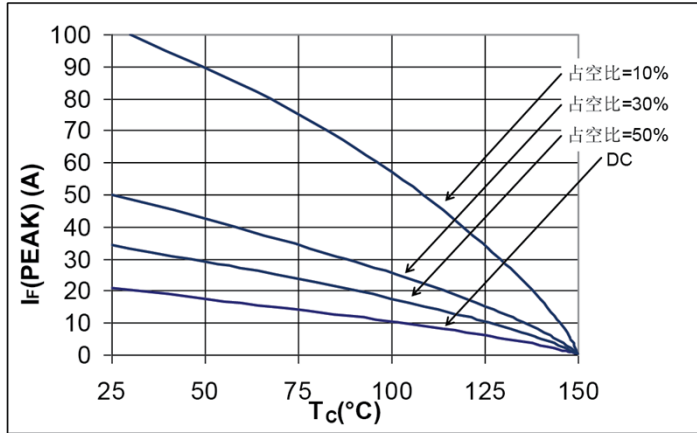
TO-220AC

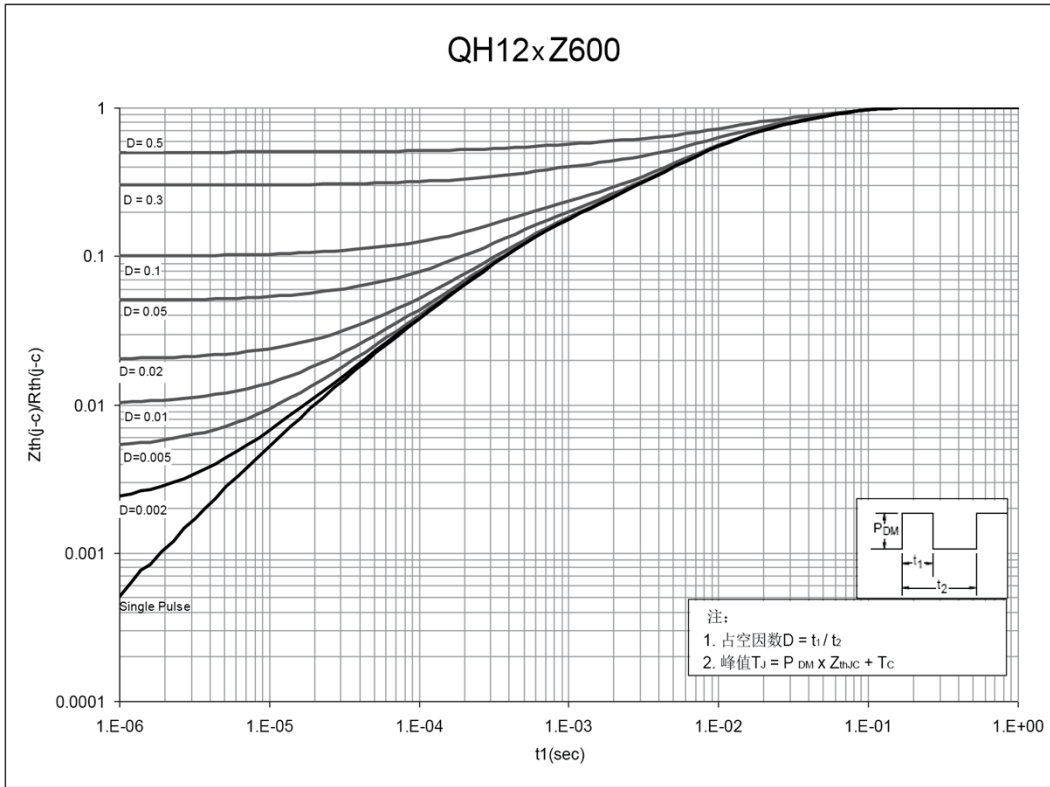
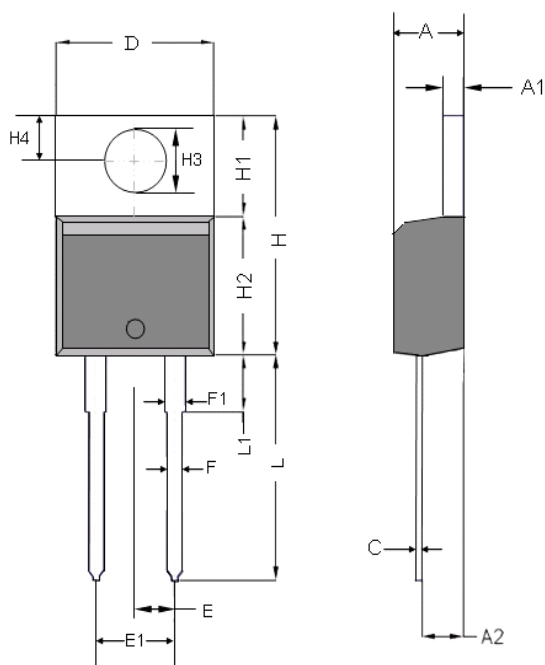

尺寸	毫米(mm)	
	最小值	最大值
A	4.32	4.70
A1	1.14	1.40
A2	2.03	2.79
C	0.34	0.610
D	9.65	10.67
E	2.49	2.59
E1	4.98	5.18
F	0.508	1.016
F1	1.14	1.78
H	14.71	16.51
H1	5.84	6.795
H2	8.40	9.00
H3	3.53	3.96
H4	2.54	3.05
L	12.70	14.22
L1	-	6.35

机械安装方法	最大扭矩/压力规格
螺丝穿过封装片中的孔	1牛米(nm)或8.8英寸磅(lb-in)
夹住封装体	每平方米12.3千克力(kgf/cm ²)或175lbf/in ²

焊接时间和温度：本产品经设计可用于高温、无铅焊接。元件引线可持续10秒承受300°C的最高温度。详细信息请参考应用指南AN-303。

元件订购信息

型号	封装	包装
QH12TZ600Q	TO-220AC	50件/管

本文档所提供的信息可能会发生变更，恕不另行通知。

修订版本	注释	日期
1.0	A版本发布。	01/21

有关最新产品信息, 请访问: www.power.com

Reference Designs are technical proposals concerning how to use Power Integrations' gate drivers in particular applications and/or with certain power modules. These proposals are "as is" and are not subject to any qualification process. The suitability, implementation and qualification are the sole responsibility of the end user. The statements, technical information and recommendations contained herein are believed to be accurate as of the date hereof. All parameters, numbers, values and other technical data included in the technical information were calculated and determined to our best knowledge in accordance with the relevant technical norms (if any). They may be based on assumptions or operational conditions that do not necessarily apply in general. We exclude any representation or warranty, express or implied, in relation to the accuracy or completeness of the statements, technical information and recommendations contained herein. No responsibility is accepted for the accuracy or sufficiency of any of the statements, technical information, recommendations or opinions communicated and any liability for any direct, indirect or consequential loss or damage suffered by any person arising therefrom is expressly disclaimed.

Power Integrations reserves the right to make changes to its products at any time to improve reliability or manufacturability. Power Integrations does not assume any liability arising from the use of any device or circuit described herein. POWER INTEGRATIONS MAKES NO WARRANTY HEREIN AND SPECIFICALLY DISCLAIMS ALL WARRANTIES INCLUDING, WITHOUT LIMITATION, THE IMPLIED WARRANTIES OF MERCHANTABILITY, FITNESS FOR A PARTICULAR PURPOSE, AND NON-INFRINGEMENT OF THIRD PARTY RIGHTS.

Patent Information

The products and applications illustrated herein (including transformer construction and circuits' external to the products) may be covered by one or more U.S. and foreign patents, or potentially by pending U.S. and foreign patent applications assigned to Power Integrations. A complete list of Power Integrations' patents may be found at www.power.com. Power Integrations grants its customers a license under certain patent rights as set forth at <http://www.power.com/ip.htm>.

Power Integrations, the Power Integrations logo, CAPZero, ChiPhy, CHY, DPA-Switch, EcoSmart, E-Shield, eSIP, eSOP, HiperPLC, HiperPFS, HiperTFS, InnoSwitch, Innovation in Power Conversion, InSOP, LinkSwitch, LinkZero, LYTSwitch, SENZero, TinySwitch, TOPSwitch, PI, PI Expert, PowiGaN, SCALE, SCALE-1, SCALE-2, SCALE-3 and SCALE-iDriver, are trademarks of Power Integrations, Inc. Other trademarks are property of their respective companies. ©2021, Power Integrations, Inc.

Power Integrations全球销售支持网络

全球总部

5245 Hellyer Avenue
San Jose, CA 95138, USA.
Main: +1-408-414-9200
Customer Service:
Worldwide: +1-65-635-64480
Americas: +1-408-414-9621
e-mail: usasales@power.com

中国 (上海)

徐汇区漕溪北路88号圣爱广场
1601-1603室
上海|中国, 200030
电话: +86-21-6354-6323
电子邮箱:
chinasales@power.com

中国深圳

南山区科技南八路二号豪威科技
大厦17层
深圳|中国, 518057
电话: +86-755-8672-8689
电子邮箱:
chinasales@power.com

德国 (AC-DC/LED业务销售)

Einsteiniring 24
85609 Dornach/Aschheim
Germany
Tel: +49-89-5527-39100
e-mail: eurosales@power.com

德国 (门极驱动器销售)

HellwegForum 3
59469 Ense
Germany
Tel: +49-2938-64-39990
e-mail: igbt-driver.sales@power.com

印度

#1, 14th Main Road
Vasanthanagar
Bangalore-560052
India
Phone: +91-80-4113-8020
e-mail: indiasales@power.com

意大利

Via Milanese 20, 3rd. Fl.
20099 Sesto San Giovanni (MI) Italy
Phone: +39-024-550-8701
e-mail: eurosales@power.com

日本

Yusen Shin-Yokohama 1-chome Bldg.
1-7-9, Shin-Yokohama, Kohoku-ku
Yokohama-shi,
Kanagawa 222-0033 Japan
Phone: +81-45-471-1021
e-mail: japansales@power.com

韩国

RM 602, 6FL
Korea City Air Terminal B/D,
159-6
Samsung-Dong, Kangnam-Gu,
Seoul, 135-728 Korea
Phone: +82-2-2016-6610
e-mail: koreasales@power.com

新加坡

51 Newton Road,
#19-01/05 Goldhill Plaza
Singapore, 308900
Phone: +65-6358-2160
e-mail: singaporesales@power.com

1 台湾地区

5F, No. 318, Nei Hu Rd.,
Sec. 1
Nei Hu District
Taipei 11493, Taiwan R.O.C.
Phone: +886-2-2659-4570
e-mail: taiwansales@power.com

英国

Building 5, Suite 21
The Westbrook Centre
Milton Road
Cambridge
CB4 1YG
Phone: +44 (0) 7823-557484
e-mail: eurosales@power.com