

The Demise of the DC-DC Converter?

A new flyback control technology with multiple independently-regulated outputs is eliminating DC-DC converters in certain applications.



Power Architecture

The power architectures of modern industrial and consumer products are liberally sprinkled with DC-DC converters, offering point-of-load regulation for various circuit subsystems. Even in products with a front-end AC-DC converter, the power system requires multiple DC-DC converters to post-regulate and provide the correct voltage and current to the output circuits. That is, until now.

A new power converter architecture challenges the dominance of output boost and buck converters and, in some cases, even the modest linear regulators that currently proliferate. Based around a novel AC-DC flyback topology employed by the InnoSwitch™3-MX and InnoMux™ chipset from Power Integrations (PI), this new technology delivers a single-stage converter with multiple independently-regulated outputs from a single magnetic component, eliminating the need for DC-DC post-regulation and therefore dramatically increasing system efficiency. This approach is already in the production of some of the latest generations of computer monitors.

To illustrate the impact of this new approach, Figure 1 shows a block diagram of a traditional power system used in modern equipment with LED displays, such as domestic appliances and computer monitors. An AC-DC stage provides an intermediate DC output rail that is then post-regulated to feed several outputs, including the LED display backlight, audio and analog circuitry and downstream processors. A boost converter steps up the intermediate rail to a variable 48 V to 60 V to support the constant current (CC) controlled LED backlight. A buck device steps down to a constant voltage (CV) 5 V rail, which is then often followed by a further buck or linear regulator (not shown) to 3.3 V rails to drive the microcontrollers.

Figure 2 shows the same system implemented with the new InnoSwitch3-MX / InnoMux chipset architecture. In addition to the component count and PCB space savings, total system power dissipation is reduced by up to 50% through elimination of the DC-DC stages.

This unprecedented level of system energy savings can greatly reduce system cost by enabling lower-eficacy displays to be employed while still meeting power consumption limits as defined by international standards, including US ENERGY STAR® 8, Japan's Top Runner Program and EU Directive 2009/125/EC for electronic display products.

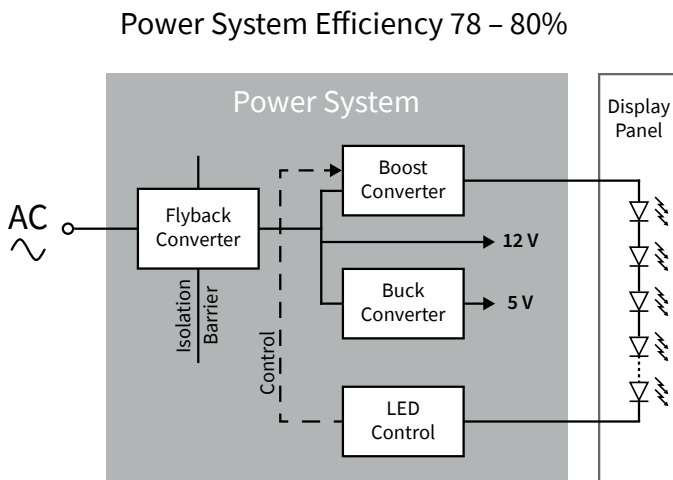

Figure 1: Traditional multi-stage DC-DC-based system

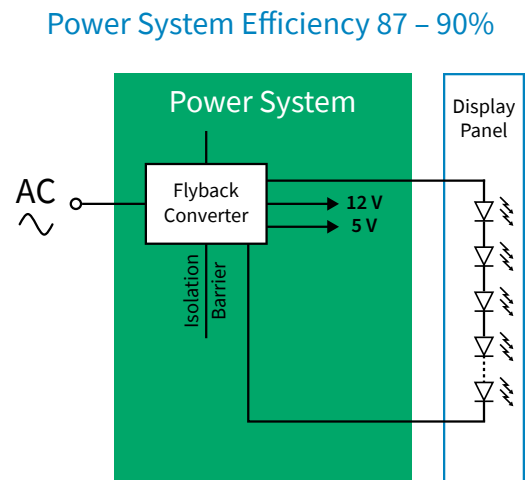

Figure 2: InnoMux-based single-stage system

The precise timing involved in multiplexing energy delivery in this way, while maintaining fault protection and optimum efficiency, is only possible due to the very high bandwidth of the FluxLink communication channel. The precise timing achieved with FluxLink also enables the use of synchronous rectification (SR) to be employed (Q1 in Figure 3), further enhancing the system efficiency by reducing the voltage drop across the output rectification component.

At first glance, the schematic in Figure 3 looks similar to a traditional multiple output flyback converter — which, of course, is nothing new. In traditional multiple output flybacks however, output voltages are fixed relative to each other through the transformer output winding turns ratio. Drawbacks include poor cross-regulation between outputs, where the voltage on heavily-loaded outputs typically droops while the voltages on more lightly loaded outputs tend to increase or ‘peak charge’. Such cross-regulation challenges are the precise reason why multi-stage converters using DC-DC converters are often the only option for system designers.

In contrast, the system in Figure 3 employs the concept of ‘energy multiplexing’ (from which InnoMux gets its name). Multiplexing energy delivery to the individual outputs according to their immediate requirements provides precise, independent regulation of each output. In addition, this capability allows some very unique power supply characteristics to be achieved. For example, some outputs can be controlled to provide constant output voltage (CV output 1 in Figure 3), while others can be controlled for constant output current (CC output 2 in Figure 3), for example to control LED display lighting or a battery charging output. A CC load necessitates the voltage of that output to be varied according to the load conditions to maintain constant load current, whereas the CV output voltage must remain fixed. This is achieved through the cycle-by-cycle energy multiplexing, allowing a 2:1 voltage adjustment on the CC output and independent regulation, and even dynamic adjustments, of each individual output voltage / current. This is achieved without impacting regulation on the other output(s). If, for example, the voltage on one output needs to be dynamically changed during standby or to meet peak load conditions, then this can be implemented by simply changing the resistor divider regulation target for that output. The energy delivery to (and therefore regulation of) the other output(s) is unaffected. These are all examples of capabilities that previously required the use of additional DC-DC post-regulation stages to make multiple converters that worked.

Synchronous buck DC-DC converters typically consist of two low resistance FETs, a power inductor and a several discrete components. As described above, the InnoMux architecture retains one of those FETs as a load switch to steer transformer energy to the desired output, and the power inductor is completely eliminated. More precisely, an InnoMux converter with n outputs requires $(n-1)$ load switches. This is explained by the fact that the lower voltage outputs divert energy when their load switches are ON, which means that the highest output voltage rail only receives energy when an energy request has been made to the primary and all output load switches are OFF. The highest output voltage rail can therefore retain a traditional diode-only configuration.

The elimination of DC-DC converters is also attractive in terms of system EMI. DC-DC converters typically operate in the 200 kHz to 500 kHz switching frequency range, introducing their own conducted and radiated EMI components to the power system. The associated EMI design considerations of PCB layout and inductor design are also eliminated in the InnoMux system.

Figure 4 shows the primary switch Drain voltage waveform. The reflected voltage for each cycle depends on which of the outputs energy is being steered to. This can be clearly seen as changes to the amplitude of the off-state VDS voltage prior to the DCM ring in each switching cycle.

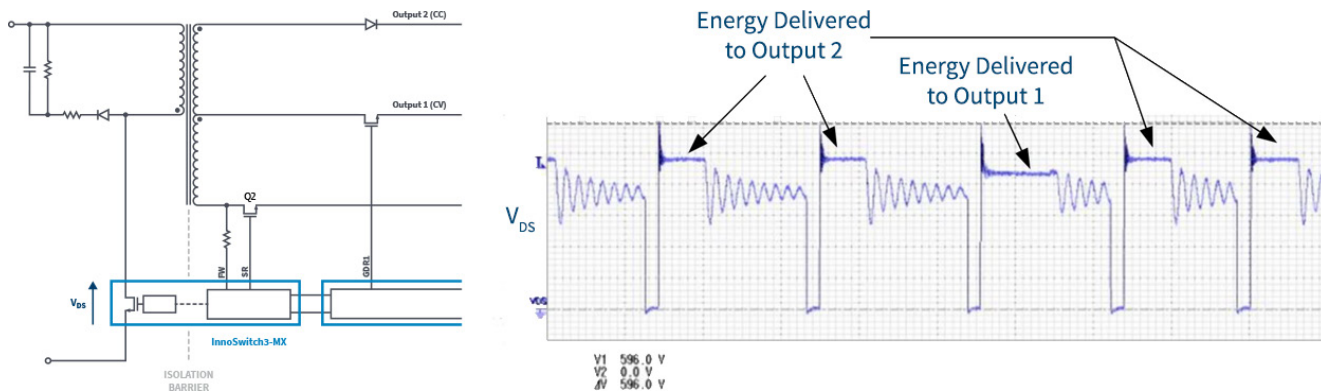

Figure 4: Typical primary drain voltage waveforms showing effect of different reflected voltages

Figure 5 shows a complete secondary schematic utilizing the full capability of the InnoMux family in a system with two CV outputs and a third CC output. The circuit is representative of a computer monitor power system, where the two CV outputs (typically 12 V and 5 V) are regulated via the FB1 and FB2 pins, while a third output, VLED, feeds a four-channel LED backlight. Pins ICC1–ICC4 receive the load current from each LED string and perform internal measurement, regulation and VLED adjustment to accurately balance the LED string currents to within less than 3%. Dimming inputs offer either analog, PWM or hybrid dimming down to 5 mA LED current per channel or 2% of maximum.

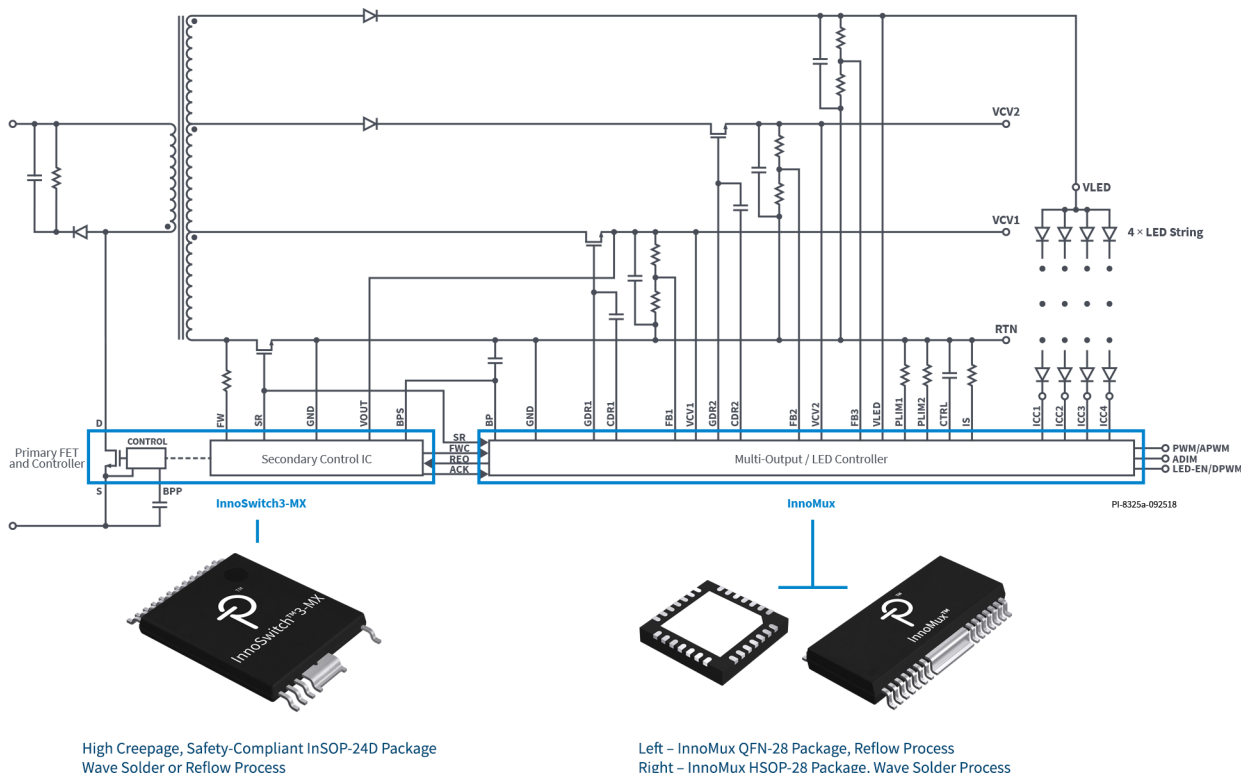

Figure 5: Two CV, one CC schematic showing four-string LED current balancing and CV output power limit settings

Another feature of the multiplexed power supply is that the system designer can choose the overload power available to each output. In Figure 5, the resistors on pins PLIM1 and PLIM2 control the maximum frequency of energy delivery to outputs VCV1 and VLED, respectively, according to the values shown in Table 1. A novel scheme using an additional capacitor on either PLIM1 or PLIM2 pins (as shown in Table 2) is used to set the maximum frequency for energy delivery to output CV2. This provides a very useful advantage over multi-output flyback converters, where traditionally components on each output must be rated to receive the full output power of the primary control circuit in an overload condition. In an InnoMux design, output components can be sized via Table 1 to support only the maximum power delivery of that specific output.

| Frequency | CV1PLIM1 | V _{LED} PLIM2 |
|-----------|----------|------------------------|
| 30 kHz | 5.1 kΩ | 5.1 kΩ |
| 41 kHz | 10 kΩ | 10 kΩ |
| 56 kHz | 22 kΩ | 22 kΩ |
| 78 kHz | 39 kΩ | 39 kΩ |

Table 1: CV1 and VLED output overload selection

| Frequency | CV1PLIM1 | V _{LED} PLIM2 |
|-----------|--------------|------------------------|
| 30 kHz | No capacitor | No capacitor |
| 41 kHz | Capacitor | No capacitor |
| 56 kHz | No capacitor | Capacitor |
| 78 kHz | Capacitor | Capacitor |

**Table 2: CV2 output overload selection
(capacitor value dependent on Table 1 resistor value)**

Figure 6 shows measured output current waveforms in a 2 CV and 1 CC application of the type shown in Figure 5.

The SR FET current waveform is a composite of all the outputs since this component conducts output current regardless of which output receives the energy. The top traces show color-coded versions of the individual output current waveforms. In the load condition shown, approximately 50% of the energy requests are routed to the LED output, 33% to the 12 V and the remaining ~17% to the 5 V output. Full-load measurements, such as those shown in Figure 6, are made during the design stage to establish the overload frequency limit for each output.

The peak current in the LED output is relatively low since the turns ratio between this output and the primary winding is the lowest of all the outputs and the current amplification is therefore also the lowest. However, since this is the highest output voltage, the power on this output is significant. As the turns ratios increase for the lower voltage 12 V and 5 V outputs, the peak currents increase. Note that the current on the 5 V output does not reach zero before the primary FET turns on. When this occurs, the current in the 5 V output winding then rapidly falls to zero. This operation is known as continuous conduction mode (CCM) operation, whereas the current waveforms on the 12 V and LED outputs are discontinuous conduction mode (DCM) waveforms (current falls to zero before the primary switch turns on). Both InnoSwitch3-MX and InnoMux ICs are designed to operate in either DCM or CCM mode to maximize flexibility in the design of the transformer.

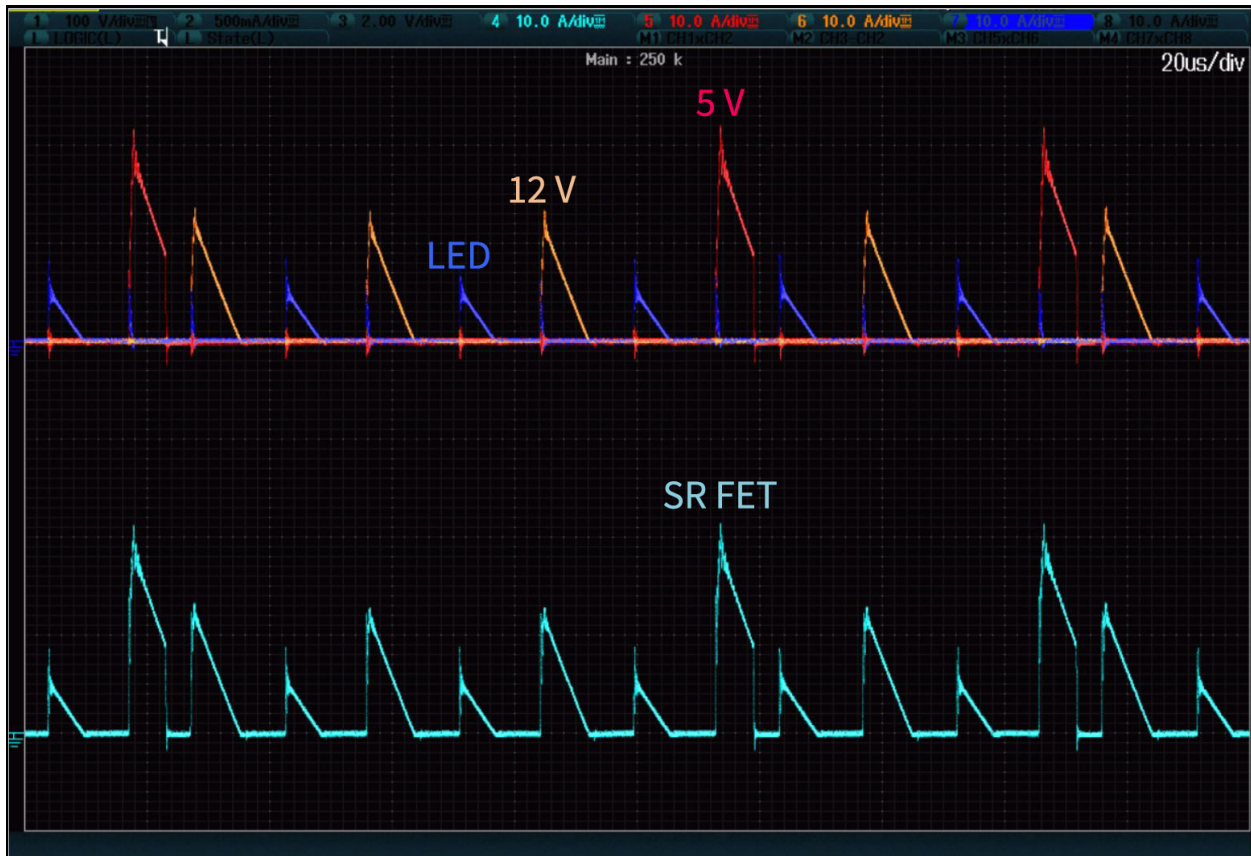
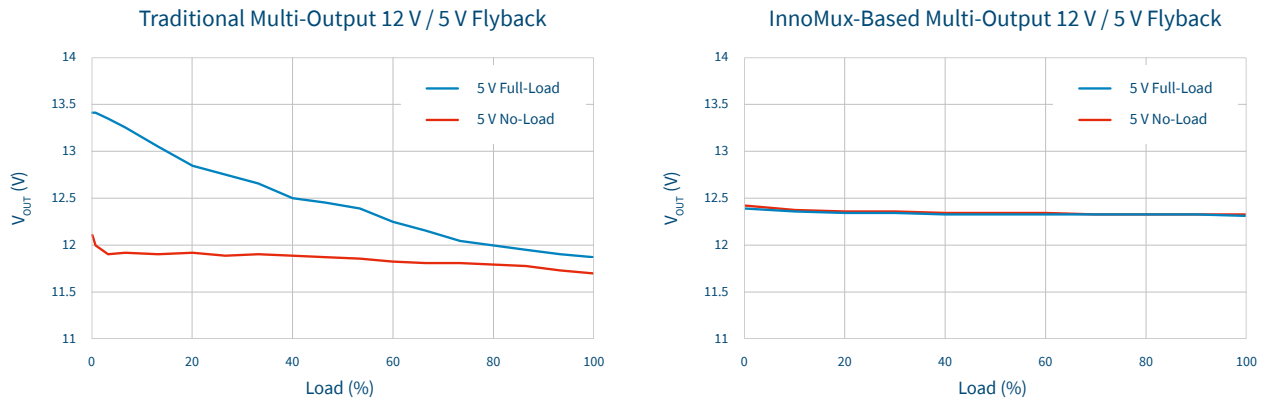

Figure 6: Output current waveforms 2 CV, 1 CC power supply

In systems that only require CV output regulation across multiple outputs, the InnoMux chipset is useful in providing accurate regulation across the full load range for each output. As mentioned earlier, traditional multi-output flybacks suffer from poor cross-regulation since their output voltages are governed by the transformer turn ratio of the outputs relative to each other. Figure 7 shows measured waveforms comparing a traditional multi-output flyback with 12 V and 5 V outputs with an InnoMux-based system. With traditional flyback converters, the power supply designer will often compromise on the regulation of one output by combining feedback information from both outputs into a single feedback node, as illustrated in Figure 8. Such schemes typically ensure that the feedback from one output (normally the 5 V) dominates and ensures that this output achieves the most accurate regulation. However, such schemes are always a compromise where the voltage regulation on each output is impacted not only by the load on that output, but also the load on the other outputs. This is shown in Figure 7.

With InnoMux, on the other hand, the truly independent feedback and regulation of each output ensures accurate regulation across the entire load range for each individual output. As previously noted, this feature set can also dynamically adjust outputs if required.

12 V Load Regulation



5 V Load Regulation

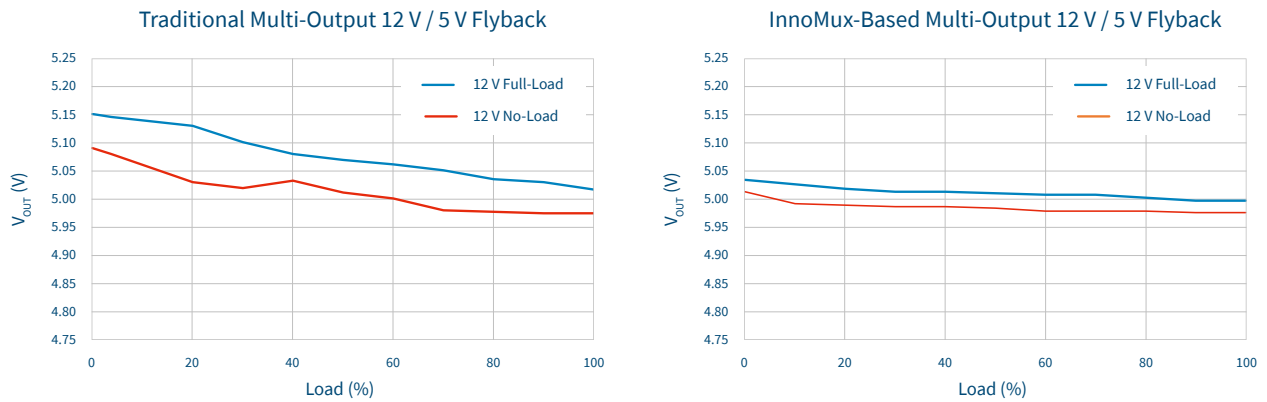

Figure 7: Measured load regulation characteristics for a 12 V / 5 V power supply using a conventional multi-output flyback versus the more accurate regulation of an InnoMux-based system

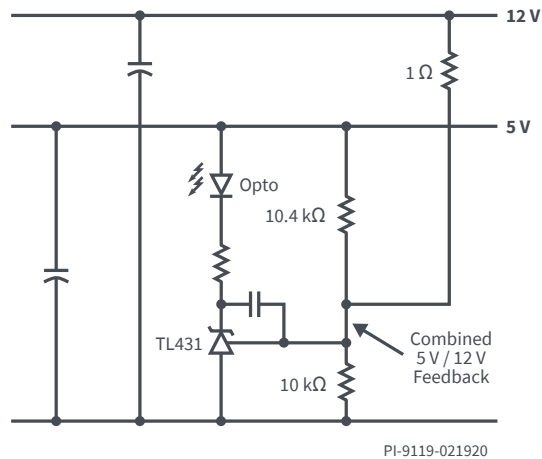

Figure 8: Traditional combined feedback scheme of multi-output flybacks, where the regulation of the 5 V output is compromised to improve the regulation of the 12 V output

Complete details of the InnoMux system operation and transformer design are beyond the scope of this article, but are supported by free design software and reference design reports available for download on the [InnoMux product page](#).

For more information,
visit power.com[™]



© 2021 Power Integrations | Power Integrations, the Power Integrations logo, power.com, InnoSwitch, InnoMux, and FluxLink are trademarks or registered trademarks of Power Integrations, Inc., in the U.S. and/or other countries.

PI-W0921-03